

# AURORA MODEL 382A-SC PUMPS

## MOTOR FRAME

### 143 HP THRU 445 HP

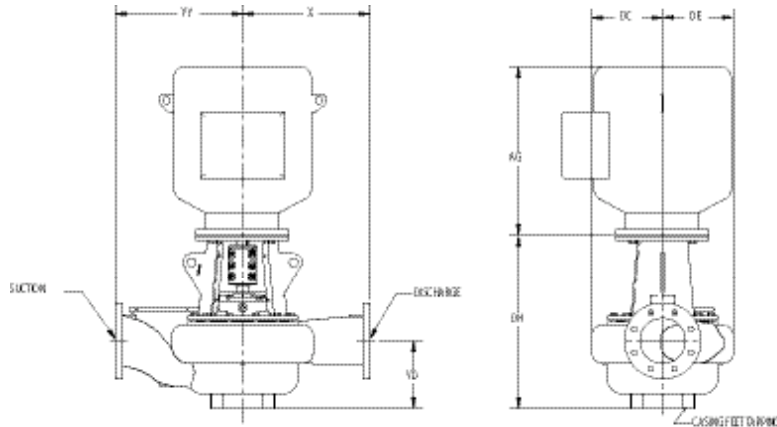

HP DIMENSION TABLE

FRAME	P	AG
143	8 (203)	11 (279)
145	8 (203)	12 (305)
182	10 (254)	14 (356)
184	10 (254)	15 (381)
213	11 (279)	16 (406)
215	11 (279)	17 (432)
254	13 (330)	20 (508)
256	13 (330)	21 (534)
284	16 (406)	22 (559)
286	16 (406)	23 (584)
324	18 (457)	25 (635)
326	18 (457)	26 (660)
364	21 (534)	25 (635)
365	21 (534)	25 (635)
404	22 (559)	28 (711)
405	22 (559)	28 (711)
444	24 (610)	32 (813)
445	24 (610)	32 (813)

PUMP SIZE			DH						YY	VD	CASING FEET TAPPING
DISCHARGE	SUCTION	CASE BORE	X	DC	DE	143 HP THRU 286 HP	324 HP THRU 445 HP				
1-1/2	1-1/2	9B	9-1/2 (241)	5-3/4 (146)	6-1/8 (156)	17-7/16 (443)	-	9-1/2 (241)	5-1/4 (133)	NOTE 8	
2	2	7	8 (203)	4-1/2 (114)	5-1/8 (130)	17-1/4 (438)	-	8 (203)	5 (127)	NOTE 9	
2	2	9A, B	9-1/2 (241)	5-7/8 (149)	6-3/8 (162)	17-7/16 (443)	-	9-1/2 (241)	5-1/4 (133)	NOTE 8	
2	2	9C	9-1/2 (241)	5-7/8 (149)	6-3/8 (162)	17 (432)	20-3/4 (527)	9-1/2 (241)	5-1/4 (133)	NOTE 9	
2	2	12	12 (305)	7-5/8 (194)	8 (203)	19-7/16 (494)	21-3/16 (538)	12 (305)	5-1/4 (133)	NOTE 8	
2-1/2	2-1/2	7	9 (229)	4-3/4 (121)	5-1/2 (140)	18 (457)	18 (457)	9 (229)	5-5/8 (143)	NOTE 10	
2-1/2	2-1/2	9	10 (254)	5-7/8 (149)	6-5/8 (168)	17-15/16 (456)	21-11/16 (551)	10 (254)	5-5/8 (143)	NOTE 10	
3	3	7A, B	9-1/2 (241)	5-3/16 (132)	6-1/8 (156)	19-1/16 (484)	19-1/16 (484)	9-1/2 (241)	6-1/4 (159)	NOTE 10	
3	3	9A	11 (279)	6 (152)	6-3/4 (171)	18-13/16 (458)	22-9/16 (573)	11 (279)	6-1/4 (159)	NOTE 10	
3	3	9B	11 (279)	6-1/4 (159)	7-1/8 (181)	18-15/16 (481)	22-11/16 (576)	11 (279)	6-1/2 (165)	NOTE 8	
3	4	9	11 (279)	5-3/4 (146)	6-1/2 (165)	18-5/16 (465)	22-1/16 (560)	11 (279)	5-7/8 (149)	NOTE 10	
3	3	12	14 (356)	7-11/16 (195)	8-1/4 (210)	20-13/16 (529)	22-9/16 (573)	12 (305)	6-1/2 (165)	NOTE 8	
4	4	7A, B	11 (279)	5-9/16 (141)	7-5/16 (186)	20-3/16 (513)	20-3/16 (513)	11 (279)	7-1/4 (184)	NOTE 10	
4	4	9A, B	11 (279)	6-3/16 (157)	7-5/16 (186)	19-13/16 (503)	23-9/16 (598)	11 (279)	7-1/4 (184)	NOTE 8	

NOTES:

- All dimensions in inches and (mm).
- Dimensions may vary ± 1/4" (6).
- Not for construction purposes unless certified.
- N/A = not applicable.
- Conduit box is shown in approximate location. Dimensions are not specified as they vary with each motor manufacturer.
- Suction and discharge flanges - 125# ANSI Standard flat face.
- Normally not tapped. Optionally available [4] 5/8" UNC taps matching 4"-125# flange drilling (7.5" bolt circle).
- Tapped [4] 5/8" UNC taps matching 2"-125# flange (4.75" bolt circle).
- Tapped [4] 5/8" UNC taps matching 3"-125# flange (6.0" bolt circle).
- Tapped [4] 5/8" UNC taps matching 4"-125# flange (7.5" bolt circle).
- Tapped [4] 3/4" UNC taps matching 6"-125# flange (9.5" bolt circle).

**AURORA MODEL 382A-SC PUMPS**  
**MOTOR FRAME**  
**143 HP THRU 445 HP**

**HP DIMENSION TABLE**

FRAME	P	AG
143	8 (203)	11 (279)
145	8 (203)	12 (305)
182	10 (254)	14 (356)
184	10 (254)	15 (381)
213	11 (279)	16 (406)
215	11 (279)	17 (432)
254	13 (330)	20 (508)
256	13 (330)	21 (534)
284	16 (406)	22 (559)
286	16 (406)	23 (584)
324	18 (457)	25 (635)
326	18 (457)	26 (660)
364	21 (534)	25 (635)
365	21 (534)	25 (635)
404	22 (559)	28 (711)
405	22 (559)	28 (711)
444	24 (610)	32 (813)
445	24 (610)	32 (813)

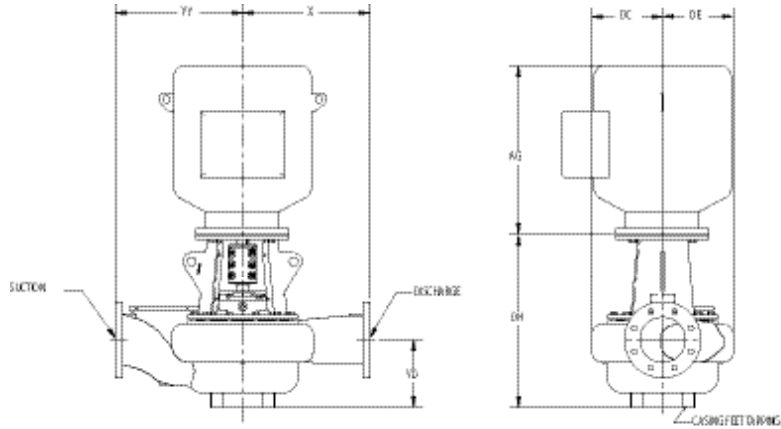

PUMP SIZE			DH							
DISCHARGE	SUCTION	CASE BORE	X	DC	DE	143 HP THRU	324 HP THRU	YY	VD	CASING FEET TAPPING
						286 HP	445 HP			
4	5	9	11 (279)	6 (152)	7-1/8 (181)	19-9/16 (497)	23-5/16 (592)	11 (279)	7 (178)	NOTE 9
4	4	11	13 (330)	7-1/8 (181)	8-1/4 (210)	22-5/16 (567)	24-1/16 (611)	13 (330)	7-5/8 (194)	NOTE 10
4	4	12	13 (330)	7-7/8 (200)	8-3/4 (222)	21-9/16 (548)	23-5/16 (592)	13 (330)	7 (178)	NOTE 10
5	5	9	14 (356)	7-1/8 (181)	8-1/2 (216)	20-7/16 (519)	24-3/16 (614)	14 (356)	7-5/8 (194)	NOTE 10
5	5	11	14 (356)	7-3/8 (187)	8-7/8 (225)	23-1/2 (597)	25-1/4 (641)	14 (356)	8-5/8 (219)	NOTE 10
5	5	12	15 (381)	8-1/4 (210)	9-1/2 (241)	22-13/16 (579)	24-9/16 (624)	15 (381)	8 (203)	NOTE 10
6	6	9	15 (381)	7 (178)	9 (229)	20-15/16 (532)	24-11/16 (627)	15 (381)	8 (203)	NOTE 10
6	6	11	15 (381)	8 (203)	10 (254)	24-1/2 (622)	26-1/4 (667)	15 (381)	9-1/4 (235)	NOTE 10
6	6	12	15 (381)	8-3/8 (213)	10 (254)	23-13/16 (605)	25-9/16 (649)	15 (381)	8-3/4 (222)	NOTE 10
8	8	11	18 (457)	8-3/4 (222)	10-7/8 (276)	25-1/8 (638)	26-7/8 (683)	18 (457)	9-5/8 (244)	NOTE 10
8	8	12	18 (457)	8-3/4 (222)	10-7/8 (276)	24-15/16 (633)	26-11/16 (678)	18 (457)	9-5/8 (244)	NOTE 10
8	8	15	22-1/2 (572)	10-3/8 (263)	12-15/16 (328)	31-1/8 (791)	31-1/8 (791)	22-1/2 (572)	12-1/8 (308)	NOTE 11
10	10	15	25 (635)	11 (279)	14-3/8 (365)	32-1/2 (826)	32-1/2 (826)	25 (635)	13-9/16 (344)	NOTE 11

**NOTES:**

- All dimensions in inches and (mm).
- Dimensions may vary  $\pm 1/4"$  (6).
- Not for construction purposes unless certified.
- N/A = not applicable.
- Conduit box is shown in approximate location. Dimensions are not specified as they vary with each motor manufacturer.
- Suction and discharge flanges - 125# ANSI Standard flat face.
- Normally not tapped. Optionally available [4] 5/8" UNC taps matching 4"-125# flange drilling (7.5" bolt circle).
- Tapped [4] 5/8" UNC taps matching 2"-125# flange (4.75" bolt circle).
- Tapped [4] 5/8" UNC taps matching 3"-125# flange (6.0" bolt circle).
- Tapped [4] 5/8" UNC taps matching 4"-125# flange (7.5" bolt circle).
- Tapped [4] 3/4" UNC taps matching 6"-125# flange (9.5" bolt circle).

# AURORA MODEL 382A-SC PUMPS

## MOTOR FRAME

### 143 HP THRU 445 HP

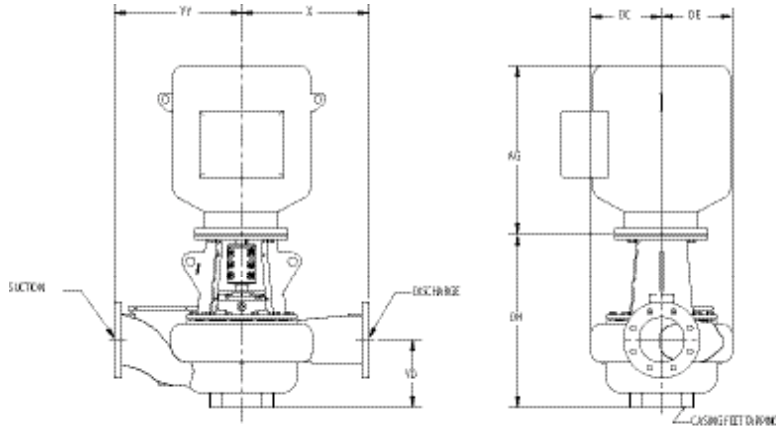

HP DIMENSION TABLE

FRAME	P	AG
143	8 (203)	11 (279)
145	8 (203)	12 (305)
182	10 (254)	14 (356)
184	10 (254)	15 (381)
213	11 (279)	16 (406)
215	11 (279)	17 (432)
254	13 (330)	20 (508)
256	13 (330)	21 (534)
284	16 (406)	22 (559)
286	16 (406)	23 (584)
324	18 (457)	25 (635)
326	18 (457)	26 (660)
364	21 (534)	25 (635)
365	21 (534)	25 (635)
404	22 (559)	28 (711)
405	22 (559)	28 (711)
444	24 (610)	32 (813)
445	24 (610)	32 (813)

PUMP SIZE			X	DC	DE	DH		YY	VD	BASE OR SUPPORT TYPE
DISCHARGE	SUCTION	CASE BORE				143 HP THRU 286 HP	324 HP THRU 445 HP			
1-1/2	1-1/2	9B	9-1/2 (241)	5-3/4 (146)	6-1/8 (156)	19-5/16 (491)	-	9-1/2 (241)	7-1/8 (181)	CAST IRON BASE
2	2	7	8 (203)	4-1/2 (114)	5-1/8 (130)	21-1/4 (540)	-	8 (203)	9 (229)	2" PIPE FLANGE
2	2	9A, B	9-1/2 (241)	5-7/8 (149)	6-3/8 (162)	19-5/16 (491)	-	9-1/2 (241)	7-1/8 (181)	CAST IRON BASE
2	2	9C	9-1/2 (241)	5-7/8 (149)	6-3/8 (162)	21 (533)	24-3/4 (629)	9-1/2 (241)	9-1/4 (235)	2" PIPE FLANGE
2	2	12	12 (305)	7-5/8 (194)	8 (203)	21-5/16 (541)	23-1/16 (586)	12 (305)	7-1/8 (181)	CAST IRON BASE
2-1/2	2-1/2	7	9 (229)	4-3/4 (121)	5-1/2 (140)	22 (559)	22 (559)	9 (229)	9-5/8 (244)	3" PIPE FLANGE
2-1/2	2-1/2	9	10 (254)	5-7/8 (149)	6-5/8 (168)	21-15/16 (557)	25-11/16 (652)	10 (254)	9-5/8 (244)	3" PIPE FLANGE
3	3	7A, B	9-1/2 (241)	5-3/16 (132)	6-1/8 (156)	23-1/16 (586)	23-1/16 (586)	9-1/2 (241)	10-1/4 (260)	3" PIPE FLANGE
3	3	9A	11 (279)	6 (152)	6-3/4 (171)	22-13/16 (579)	26-9/16 (675)	11 (279)	10-1/4 (260)	3" PIPE FLANGE
3	3	9B	11 (279)	6-1/4 (159)	7-1/8 (181)	20-13/16 (529)	24-9/16 (624)	11 (279)	8-1/8 (206)	CAST IRON BASE
3	4	9	11 (279)	5-3/4 (146)	6-1/2 (165)	22-5/16 (567)	26-1/16 (662)	11 (279)	9-7/8 (251)	3" PIPE FLANGE
3	3	12	14 (356)	7-11/16 (195)	8-1/4 (210)	22-11/16 (576)	24-7/16 (621)	12 (305)	8-1/8 (206)	CAST IRON BASE
4	4	7A, B	11 (279)	5-9/16 (141)	7-5/16 (186)	24-3/16 (614)	24-3/16 (614)	11 (279)	11-1/4 (286)	3" PIPE FLANGE
4	4	9A, B	11 (279)	6-3/16 (157)	7-5/16 (186)	21-11/16 (576)	25-7/16 (646)	11 (279)	9-1/8 (232)	CAST IRON BASE

NOTES:

1. All dimensions in inches and (mm).
2. Dimensions may vary ± 1/4" (6).
3. Not for construction purposes unless certified.
4. N/A = not applicable.
5. Conduit box is shown in approximate location. Dimensions are not specified as they vary with each motor manufacturer.
6. Suction and discharge flanges - 125# ANSI Standard flat face.

**AURORA MODEL 382A-SC PUMPS**  
**MOTOR FRAME**  
**143 HP THRU 445 HP**

HP DIMENSION TABLE

FRAME	P	AG
143	8 (203)	11 (279)
145	8 (203)	12 (305)
182	10 (254)	14 (356)
184	10 (254)	15 (381)
213	11 (279)	16 (406)
215	11 (279)	17 (432)
254	13 (330)	20 (508)
256	13 (330)	21 (534)
284	16 (406)	22 (559)
286	16 (406)	23 (584)
324	18 (457)	25 (635)
326	18 (457)	26 (660)
364	21 (534)	25 (635)
365	21 (534)	25 (635)
404	22 (559)	28 (711)
405	22 (559)	28 (711)
444	24 (610)	32 (813)
445	24 (610)	32 (813)

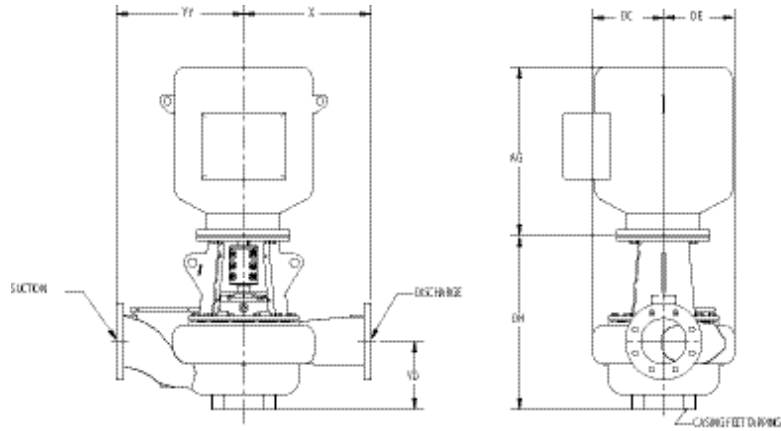

PUMP SIZE					DH					
DISCHARGE	SUCTION	CASE BORE	X	DC	DE	143 HP THRU 286 HP	324 HP THRU 445 HP	YY	VD	CASING FEET TAPPING
4	5	9	11 (279)	6 (152)	7-1/8 (181)	23-9/16 (598)	27-5/16 (694)	11 (279)	11 (279)	3" PIPE FLANGE
4	4	11	13 (330)	7-1/8 (181)	8-1/4 (210)	27-5/16 (694)	29-1/16 (738)	13 (330)	12-5/8 (321)	4" PIPE FLANGE
4	4	12	13 (330)	7-7/8 (200)	8-3/4 (222)	26-9/16 (675)	28-5/16 (719)	13 (330)	12 (305)	4" PIPE FLANGE
5	5	9	14 (356)	7-1/8 (181)	8-1/2 (216)	25-7/16 (646)	29-3/16 (741)	14 (356)	12-5/8 (321)	4" PIPE FLANGE
5	5	11	14 (356)	7-3/8 (187)	8-7/8 (225)	28-1/2 (724)	30-1/4 (768)	14 (356)	13-5/8 (346)	4" PIPE FLANGE
5	5	12	15 (381)	8-1/4 (210)	9-1/2 (241)	27-13/16 (706)	29-9/16 (751)	15 (381)	13 (330)	4" PIPE FLANGE
6	6	9	15 (381)	7 (178)	9 (229)	25-15/16 (659)	29-11/16 (754)	15 (381)	13 (330)	4" PIPE FLANGE
6	6	11	15 (381)	8 (203)	10 (254)	29-1/2 (749)	31-1/4 (794)	15 (381)	14-1/4 (362)	4" PIPE FLANGE
6	6	12	15 (381)	8-3/8 (213)	10 (254)	28-13/16 (732)	30-9/16 (776)	15 (381)	13-3/4 (349)	4" PIPE FLANGE
8	8	11	18 (457)	8-3/4 (222)	10-7/8 (276)	30-1/8 (765)	31-7/8 (810)	18 (457)	14-5/8 (371)	4" PIPE FLANGE
8	8	12	18 (457)	8-3/4 (222)	10-7/8 (276)	29-15/16 (760)	31-11/16 (805)	18 (457)	14-5/8 (371)	4" PIPE FLANGE
8	8	15	22-1/2 (572)	10.34 (263)	12.91 (328)	37-1/8 (943)	37-1/8 (943)	22-1/2 (572)	18-1/8 (460)	6" PIPE FLANGE
10	10	15	25 (635)	11 (279)	14.38 (365)	38-1/2 (978)	38-1/2 (978)	25 (635)	19-9/16 (497)	6" PIPE FLANGE

NOTES:

1. All dimensions in inches and (mm).
2. Dimensions may vary  $\pm 1/4"$  (6).
3. Not for construction purposes unless certified.
4. N/A = not applicable.
5. Conduit box is shown in approximate location. Dimensions are not specified as they vary with each motor manufacturer.
6. Suction and discharge flanges - 125# ANSI Standard flat face.