

# INSTRUCTION AND REPAIR MANUAL

## SERIES 382A-SC

# 6

### APPLICATIONS:

The 382A-SC Series is a superior commercial in-line pump based on the Aurora Pump 340/380 series which has been manufactured and field tested under the severest demands of high temperature condensate service and boiler feed applications for over 50 years. Pumping applications for the 382A-SC include: hot or chilled water circulation, pressure booster systems, and cooling towers for office buildings, hotels, hospitals, universities and warehouses.

### OPERATIONAL LIMITS

Maximum Operating Pressure: 175 psi  
Maximum Operating Temperature: 225°F (107°C)

### ATTENTION: SAFETY WARNINGS:

Read and understand all warnings before installation or servicing pump.

### ELECTRICAL SAFETY:

#### **Warning:** Electrical Shock Hazard

All electrical connections are to be made by a qualified electrician in accordance with all codes and ordinances. Failure to follow these instructions could result in serious personal injury, death or property damage.

#### **Warning:** Electrical Overload Hazard

Insure all motors have properly sized overload protection. Failure to follow these instructions could result in serious personal injury, death or property damage.

#### **Warning:** Sudden Start-Up Hazard

Disconnect and lockout power source before servicing. Failure to follow these instructions could result in serious personal injury, death or property damage.

### HIGH TEMPERATURE SAFETY:

#### **Warning:** Hot Surface Hazard

If pumping hot water, insure guards or proper insulation is installed to protect against skin contact to hot piping or pump components. Failure to follow these instructions could result in serious personal injury, death or property damage.

#### **Warning:** Spraying Water Hazard

When servicing pump replace all gaskets and seals. Do not re-use old gaskets or seals. Failure to follow these instructions could result in serious personal injury, death or property damage.

### HIGH PRESSURE SAFETY:

#### **Warning:** High Pressure Hazard

The pump is rated at a maximum of 175 psi (155 psi). Do not exceed this pressure. Install properly sized pressure relief valves in system. Failure to follow these instructions could result in serious personal injury, death or property damage.

#### **Warning:** Expansion Hazard

Water expands when heated. Install properly sized thermal expansion tanks and relief valves. Failure to follow these instructions could result in serious personal injury, death or property damage.

### INSTALLATION:

The 382A-SC pump must be installed vertically. Install isolating valves on each side of pump so pump maintenance can be performed without draining the system. Special mounting requirements may be required if the pump is to be mounted near a noise or vibration sensitive area.

A minimum length of straight pipe is required on the suction side of the pump. Five times the pipe diameter is sufficient to allow a smooth entry of water into the pump.

Suction and discharge piping must be in line. Do not use pump casing to force the alignment of the piping. Properly support the piping to provide a rigid support for the pump. Tighten pump flanges evenly to prevent flange cocking and liquid leakage. Do not reuse old gaskets.

### ELECTRICAL CONNECTIONS:

#### **Warning:** Electrical Shock Hazard

All electrical connections are to be made by a qualified electrician in accordance with all codes and ordinances. Failure to follow these instructions could result in serious personal injury, death or property damage.

#### **Warning:** Electrical Overload Hazard

Insure all motors have properly sized overload protection. Failure to follow these instructions could result in serious personal injury, death or property damage.

#### **Warning:** Sudden Start-Up Hazard

Disconnect and lockout power source before servicing. Failure to follow these instructions could result in serious personal injury, death or property damage.

## MODEL 382A-SC

### START UP:

The pump must be filled with water before start up or the mechanical seal will not be lubricated and will fail. Loosen vent plug on pump casing to insure all air is vented from casing and the casing is filled with water.

#### **Warning:** Hot Surface Hazard

If pumping hot water, insure guards or proper insulation is installed to protect against skin contact to hot piping or pump components. Failure to follow these instructions could result in serious personal injury, death or property damage.

#### **Warning:** Spraying Water Hazard

When servicing pump, replace all gaskets and seals. Do not re-use old gaskets or seals. Failure to follow these instructions could result in serious personal injury, death or property damage.

Avoid all situations where pipe stain may be transferred to the pump casing. Expansion fittings and pipe hangers located close to the pump may be required. Do not force the piping to match the pump suction and discharge flanges. Re-cut the piping to avoid this situation.

All electrical connections are to be completed by a qualified electrician. Insure properly sized overload protection is installed.

### OPERATING:

Insure the system is filled with water and vented prior to pump start up. The pump rotation is clockwise when viewed from the back of the motor. Do not run the pump dry or the mechanical seal will be destroyed.

### MAINTENANCE AND SERVICE TO THE PUMP:

The 382A-SC pump requires no regular service other than periodic inspection and occasional cleaning. A periodic inspection must be performed looking for seal leaks indicating the mechanical seal is worn out and any unusual noise or vibration that will indicate other pump components require service/repair. The motor may require lubrication; the motor manufacturer's recommendation should be followed.

### REPAIRS:

**READ AND UNDERSTAND ALL SAFETY WARNINGS AT THE BEGINNING OF THE MANUAL BEFORE BEGINNING INSTALLATION OR ANY REPAIR WORK.**

This repair manual is broken into two sections. The first section covers the replacement of the mechanical seal. The second section covers complete pump disassembly. Refer to the exploded pump diagram for item numbers.

## SECTION 1

### Replacing the Mechanical Seal

1. Insure the electrical power is locked out, the system pressure has been lowered and temperature of the unit is at a safe level.
2. Isolate the pump from the system by closing the valves that should be located on the suction and discharge side of the pump. Loosen one of the pipe plugs (#4) and drain the pump.
3. Remove the coupling guards (#17) by removing the four (per side) retaining bolts (#4). Loosen the feral nuts on the tubing connectors (#1) and remove the gland flushing tubing (#3).
4. Remove the four gland bolts (#55) and utilizing the two wing nuts (#52) jack the seal gland (#44) upward until the top surface of the seal gland is in firm contact with the bottom of the retaining ring (#41A). With the wing nuts finger tight against the gland the weight of the shaft (#40) and impeller (#11) can now be supported by the

gland and the split coupling can be removed without the shaft dropping.

5.

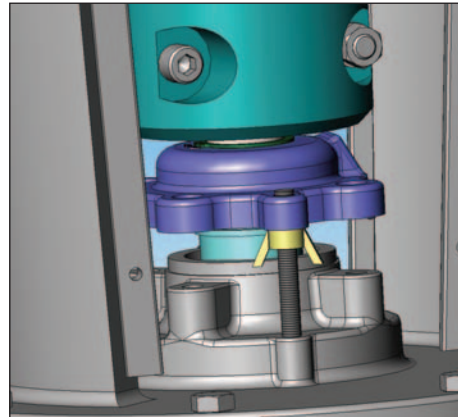

6.

Remove the six socket head coupling bolts (#48) along with the nuts (#50) and lock washer (#49). The two coupling halves (#45) can now be pulled away from the shaft.

7. Remove the two annular (round) keys (#46 & #47) as well as the two linear (square) keys (#53 & #54).
8. Carefully lower the shaft impeller assembly by backing off on the two gland supporting wing nuts until the face of the impeller rests inside the casing.
9. Remove the snap ring (#41A) from the shaft.
10. The gland (with the stationary seat of the mechanical seal pressed internally) can be removed through the gap present between the pump shaft and the motor shaft.
11. Pry the old mechanical seal rotating head (#27) up and off the pump shaft. Remove the stationary seat of the mechanical seal from the gland. Remove the O-Ring gasket (#43) from the groove on the bottom of the gland. Clean all surfaces, checking for nicks and sharp edges that may damage the elastomers on the mechanical seal or the gland.

**If the pump is to be fully disassembled stop at this point and proceed to Step 1 under the section titles "Complete Pump Disassembly"**

12. To replace the mechanical seal, lubricate the stationary seat bore in the gland with soapy water mixture and press in the seat insuring it is flat in the bore. Replace the gland o-ring, holding in the groove with a small amount of non-hardening silicon or grease.
13. Lubricate the pump shaft with a soapy water and first place the spring retainer over the shaft, followed by the spring and finally the rotating head of the seal.
14. Place the gland down on the shaft and insure the two jacking holes on the side of the gland are engaged with threaded rod and wing nuts.
15. Replace the external retaining ring making sure it is in the groove of the shaft.
16. Using 1/2 of the split coupling as a guide, (the thin groove cut into the top of the coupling identifies the motor side of the coupling), utilize the wing nuts to raise the shaft (with impeller) upward to align the annular grooves on the coupling with the grooves on the shaft. Place one half of the motor annular key in the motor shaft groove. Place the linear motor key in the motor shaft. Place the linear pump key in the pump shaft and align the two linear keys so the coupling half fits both motor and pump shaft. Slide in the pump shaft annular key half (additional adjustment of the wing nuts may

## MODEL 382A-SC

be necessary as the key to groove fit is close). Place the second pump shaft and motor annular keys in their respective grooves and rotate the key 90 degrees so they stay in place. Place the other half of the split coupling onto the shafts. Replace the 6 socket head cap screws (3 sockets facing in on one side and 3 facing out on the other side requiring rotating the shaft 180 degrees to tighten the cap screws) and add lock washers and nuts. Adjust the socket head cap screws so the gap between the coupling halves is even. Tighten the socket head cap screws in a crosswise pattern to the torque listed in the table below.

<b>Split Coupling Bolt Tightening Torque</b>		
<b>Bolt Size</b>	<b>Hex Socket Size</b>	<b>Torque (ft-lbs)</b>
3/8 inch	5/16	35
1/2 inch	3/8	90

17. Lower the gland by utilizing the wing nuts, replace the four gland bolts and tighten the gland down evenly. After the gland is tightened down, tighten the two wing nuts to the under side of the gland (holding them stationary and preventing them from vibrating).
18. Reinstall the flush tubing. Insure the coupling rotates freely with no dragging or binding. Replace the coupling guards and refer to the beginning of the manual for start up instructions.

### **COMPLETE PUMP DISASSEMBLY:**

1. With the coupling, gland and mechanical seal removed, remove the bolts (#26) and nuts (#31) holding the motor to the bracket (#35). Pull the motor up and away utilizing suitable lifting equipment.
2. Remove the snap ring (#41B) from the shaft (#40).
3. Remove the cap screws (#27) holding the bracket (#35) to the casing (#6). Utilizing suitable lifting equipment lift the bracket straight up and off the casing and over the shaft. Take care when lifting to insure a straight lift, the carbon bushing (#42) may be damaged by uneven lifting.
4. Remove the casing gasket (#8) from the casing and bracket.
5. Remove wear rings (#7, #16) from the casing and bracket.
6. Press out the carbon bushing (#42) from the bore inside the bracket (at the base of the packing box). During reassembly the new bushing must be pressed in evenly or it can crack.
7. Pump reassembly is performed in the reverse order.

MODEL 382A-SC

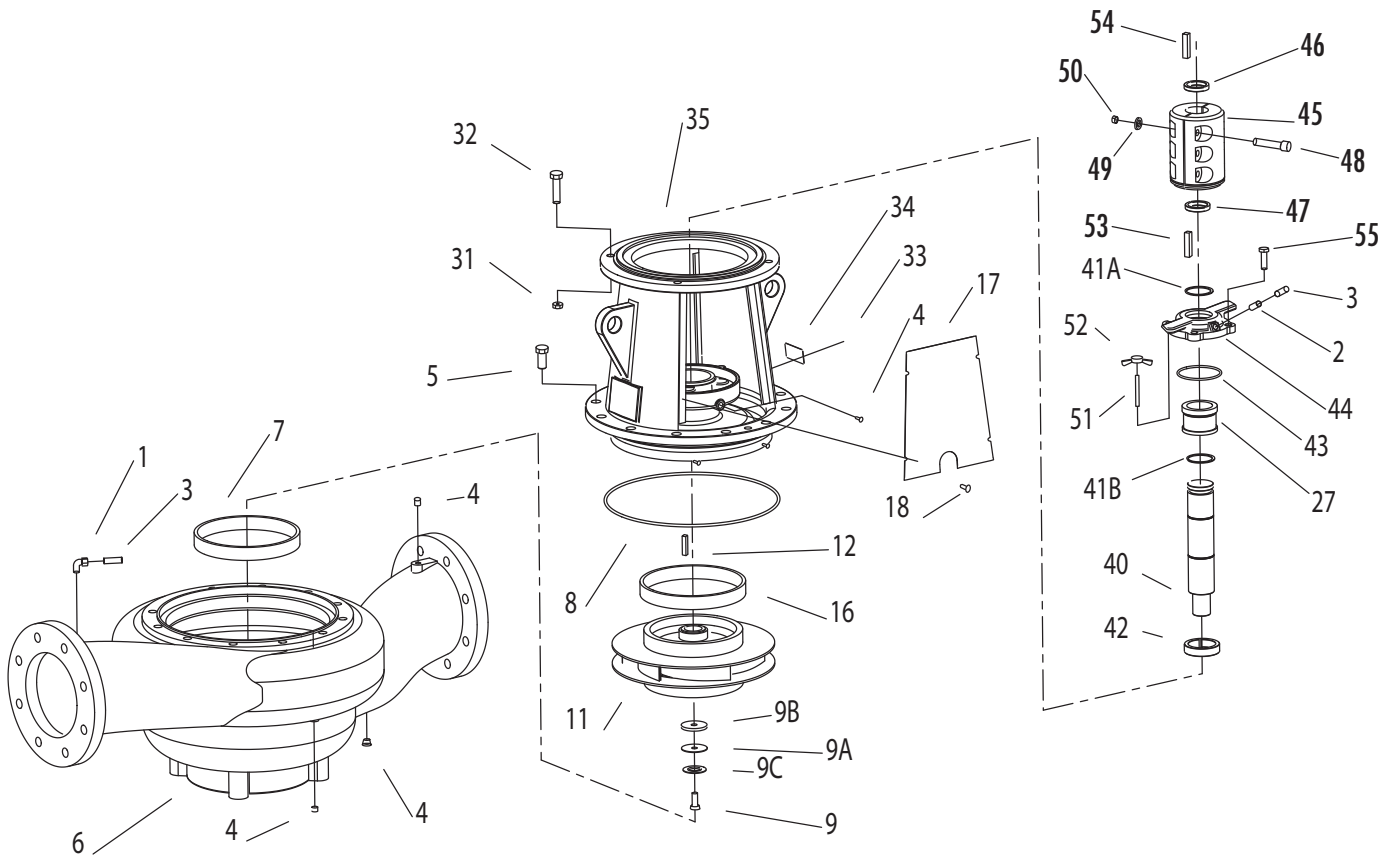





**NOTE:**

Aurora Pump reserves the right to make revisions to its products and their specifications, and to this bulletin and related information without notice.

**Aurora Pump**

800 Airport Road  
North Aurora, IL 60542  
phone: 630-859-7000  
fax: 630-859-7060